

LIGHT MATERIAL BUCKET LGS-XL

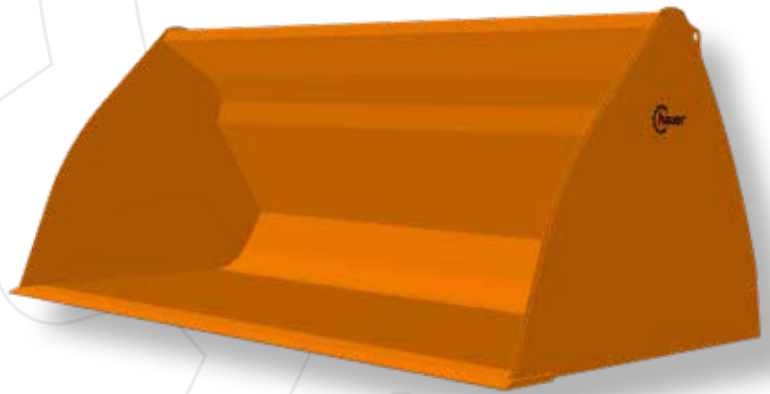

Application:

The Hauer light material bucket LGS-XL allows machine owners to use their front-end loader for handling large volumes of light bulk materials such as grain, woodchips and snow.

Operating principle:

Made from high-quality materials, the bucket features a low kerb weight and a high payload and the curved design ensures the high volume is exploited to the fullest.

Advantages:

- High volume
- Sturdy design
- Low kerb weight

Standard specifications:

- SWE-B mount (Hauer system) or SWE-Euro mount (Euro Hook)
- Standard Hauer orange or Hauer matt black paint finish

Options:

- Multiple mount options
- Paint finish available in all RAL colours
- Additional cutting edge



INNOVATION WITH TRADITION FOR LIFE.

Technical data:

Width B mm	Volume m ³	Depth T mm	Height H mm	Weight kg
2000	1,56	1275	1030	346
2200	1,73	1275	1030	379
2400	1,89	1275	1030	422
2550	2,00	1275	1030	444

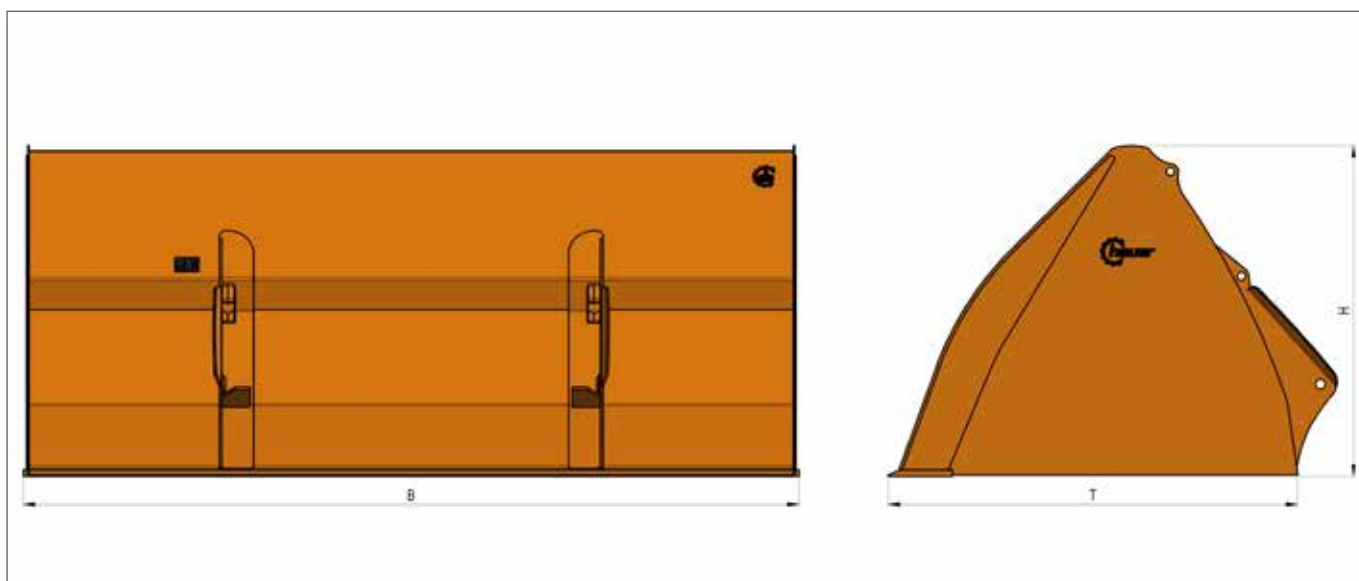

© Hauer 2024/11. Images shown may differ from standard delivery. Errors excepted and technical changes reserved.