

TOOL BOX WITH BALLAST



Application:

The tool box with ballast is the optimal solution to store tools practically and safely and at the same time to provide sufficient ballasting for the tractor.

Operating Principle:

Just as with the Hauer 3-point weights, the tool boxes with ballast also have a very compact design and are therefore particularly suitable for a variety of work and still are universally usable. The cover is held in place by a gas pressure damper. The latches of the cover can be locked at the front with a padlock or similar.

Advantages:

- compact and sturdy design
- sealed and lockable storage room
- durable 2-coat 2-components paint
- weight in suitable sizes



INNOVATION WITH TRADITION FOR LIFE.

Standard specification:

- hooks category 2/3 (depending on size)
- standard Hauer black matt or Hauer orange (optional all RAL colours)
- cover with gas pressure damper
- reflective stripes
- anti-slip mat

Options:

- side marker lamps
- head light
- underride protection, incl. side marker lamps
- divider
- work bench
- draw bar
- front limit indicator with draw bar bolt
- attachment frame front weight for coupling plate DIN 76060-B Euro size 3
- name badge (max. 10 letters)
- paint finish available in all RAL colours



Tool box standard equipment



Tool box standard equipment



Tool box fully equipped



Tool box fully equipped



Work bench folded out



Work bench folded in



Draw bar

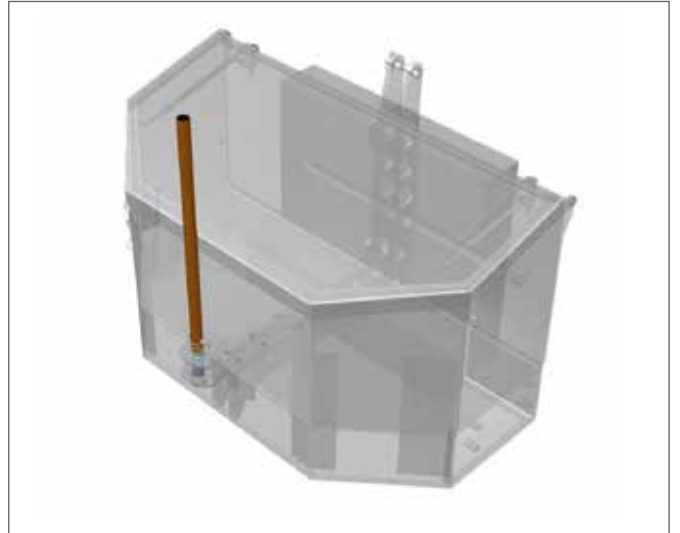

Front limit indicator with draw bar bolt



Underride protection, incl. side marker lamps



Attachment frame front weight for coupling plate
DIN 76060-B Euro size 3

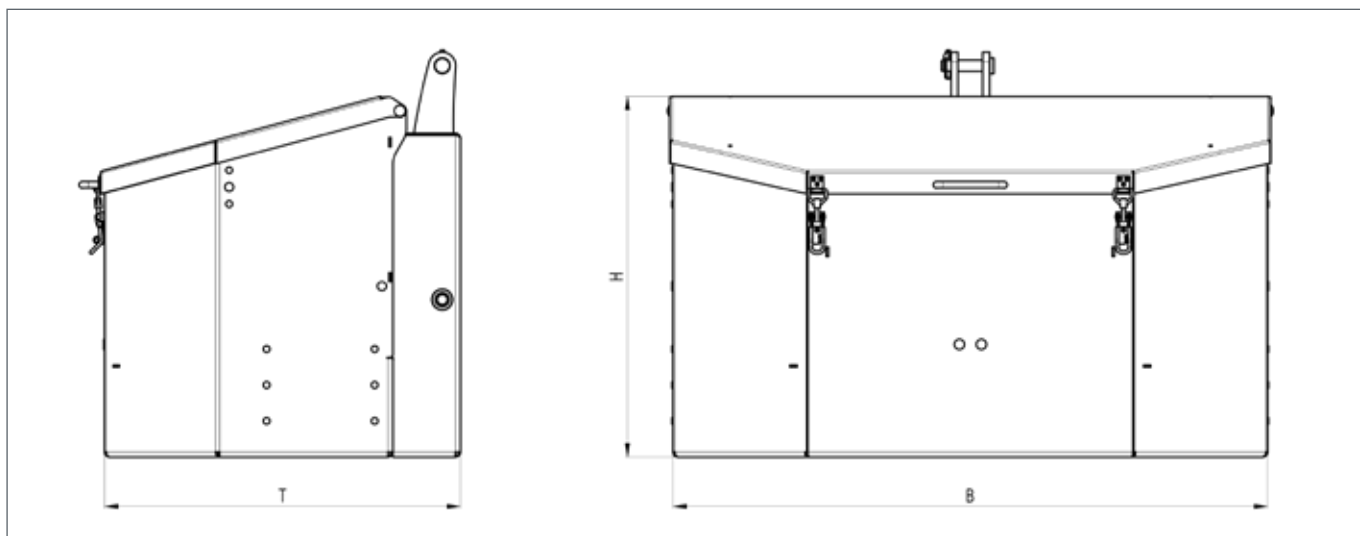

Technical data	Width * mm (B)	Depth * mm (T)	Height * mm (H)	Hooks Category	Filling volume l	Weight kg
Tool box with ballast 450 kg	1345	845	800	2/3	380	450
Tool box with ballast 700 kg	1345	845	800	2/3	380	700
Tool box with ballast 1000 kg	1645	845	800	2/3	475	1000
Tool box with ballast 1250 kg	1645	845	800	2/3	380	1250
Tool box with ballast 1500 kg	1645	960	800	2/3	325	1500

(*ohne Zugmaul)

© Hauer 07/2024. Images shown may differ from standard delivery. Errors excepted and technical changes reserved.



Franz Hauer GmbH & CoKG, A-3125 Statzendorf, Werksstraße 6,

Tel.: +43 / (0)2786 / 7104-0 | info@hfl.co.at | www.hfl.co.at