

BALE FORK BTG 4



Application:

The BTG 4 bale fork is a universal implement for hay and straw bale handling. The well-proven and opening spikes have rollers that slide onto the spikes to protect film wrap on round bales. Die BTG 4 is especially designed for the transport and stacking of lying bales without reducing the lifting height.

Operating principle:

The two spikes are controlled by a double-acting cylinder and open to variable widths of 660 mm to 1560 mm, enabling fast handling of bales of common sizes.

The unit is supplied with standard quick-fit rollers that rotate around the spikes for gentle handling and protection of film wrap. With spike length restricted to 1050 mm, the handler will not damage other bales in the stack.

A combined 3-point/Euro mount is an option for easy attachment to different loaders without tools.

An equaliser bar is an option that keeps the arms synchronised in movement and an optional check valve secures the fork in transport position for safe travel on public roads.

The extremely resistant 2K two-stage paint coat offers superb protection from corrosion and can be refinished in the course of a long service life.

Advantages:

- Large 660 - 1560 mm opening
- 1050 mm spike length avoids damaging other bales in the stack
- Large choice of bolt-on mounting plates



INNOVATION WITH TRADITION FOR LIFE.

Spike length mm	Opening mm	Weight kg
1050	660 - 1560	180

Standard specification:

- SWE-B mount (Hauer system) or SWE-Euro mount
- Standard Hauer orange or Hauer matt black paint finish
- Quick-fit rotating rollers
- Bolted mounting plates
- Double-acting cylinder

Options:

- Equaliser bar
- Multiple mount options
- Check valve
- Additional 3-point linkage coupling and combined Euro/3-point mount
- Paint finish available in all RAL colours

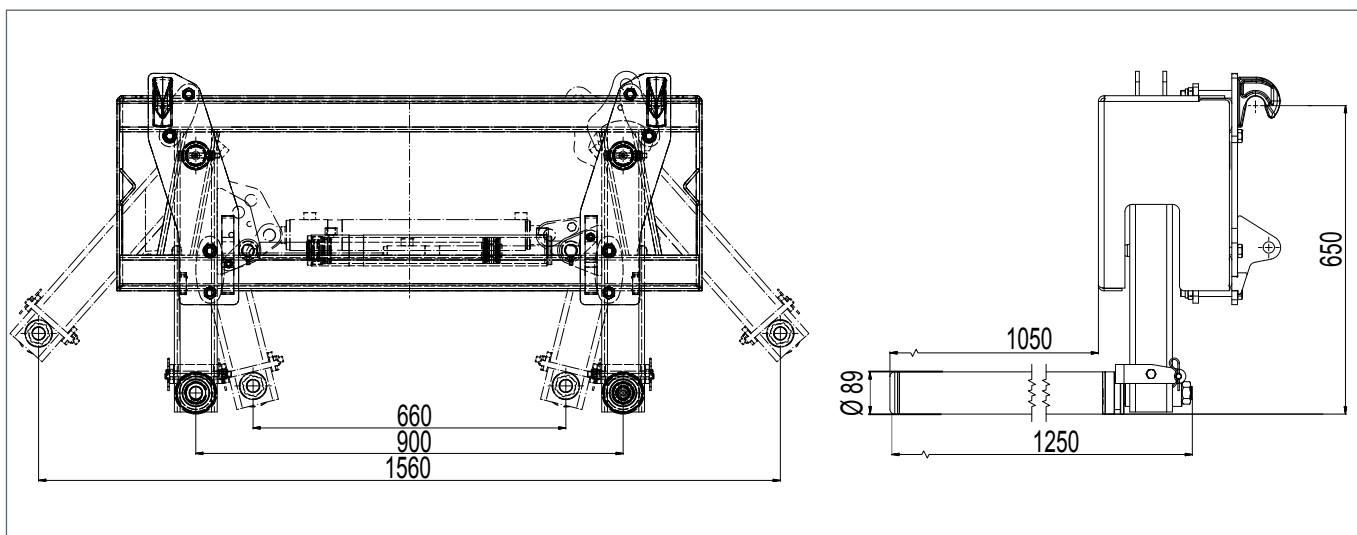

© Hauer 02/2024. The illustrated products may differ from standard specification products. Subject to errors and changes..

