

# LIGHT MATERIAL BUCKET LGS



## Application:

The Hauer light material bucket is a bespoke development for handling snow, grain, woodchips and similar materials.

## Description:

The Hauer light material bucket has a curved back with a smooth surface. It has welded and right-angle sides that prevent material from compressing and sticking to the back wall. The welded cutting edge is made from high-tensile and hard-wearing 450 HB steel for maximum protection and longevity. A small angle on the back of the bucket allows users to use the attachment also for grading.

The bucket is available as a long and a short version with lower depth and height.

The long version from 2000 mm width is available as a heavy-duty version which offers a reinforced cutting edge, reinforced side blades and sides and an angle on the back wall.

All models are available with an additional cutting edge as an option which is bolted under the welded cutting edge. This additional edge has two chamfered edges and is reversible to double the life of the product. The extremely resistant 2K two-stage paint coat offers superb protection from corrosion and can be refinished in the course of a long service life.



INNOVATION WITH TRADITION FOR LIFE.

## Advantages:

- Great longevity from high-quality materials
- Large volume, low dead weight
- An angle on the back for grading
- Versatile use
- Precise mounting angles for parallel guidance
- Curved back prevents material from compressing and sticking to the back wall
- Cutting edge made from high-tensile and hard-wearing 450 HB steel

Design	Width B mm	Volume m <sup>3</sup>	Height H mm	Depth T mm	Weight kg
short	1800	0,68	670	870	182
short	2000	0,76	670	870	195
short	2200	0,84	670	870	221
short	2400	0,92	670	870	234
long	1800	0,92	800	1000	223
long	2000	1,02	800	1000	239
long	2200	1,12	800	1000	268
long	2400	1,23	800	1000	287
long, reinforced	2000	1,02	800	1000	280
long, reinforced	2200	1,12	800	1000	323
long, reinforced	2400	1,23	800	1000	344
long, reinforced	2600	1,34	800	1000	365

## Standard specification:

- SWE-B mount (Hauer system) or SWE-Euro mount (Euro Hook)
- Standard Hauer orange or Hauer matt black paint finish

## Options:

- Multiple mount options
- Second bolt-on cutting edge (reversible)
- Paint finish available in all RAL colours

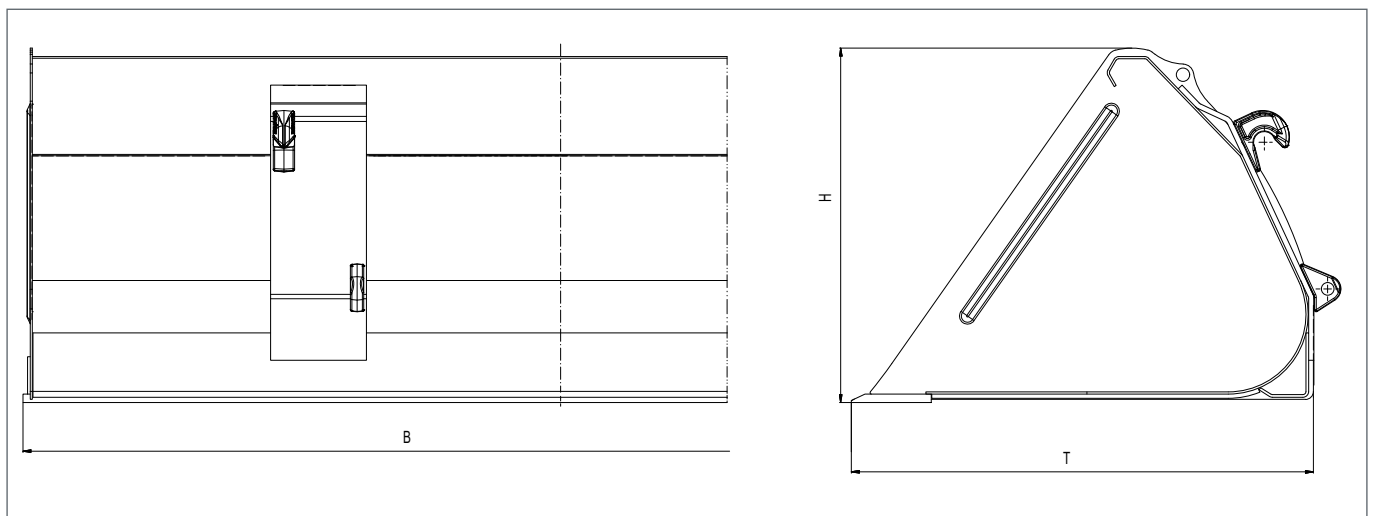

© Hauer 08/2020. The illustrated products may differ from standard specification products. Subject to errors and changes.



Franz Hauer GmbH & CoKG, A-3125 Statzendorf, Werksstraße 6,

Tel.: +43 / (0)2786 / 7104-0, info@hfl.co.at | www.hfl.co.at